

| | | | |
|----------|-----------|------------|---------|
| GAMA | CÓDIGO | MODELO | FUNCIÓN |
| MI - IIO | CRI306050 | NFT109GTMC | Fry Top |

PRODUCTO

Fry-top a gas con placa 1/3 ranurada y 2/3 lisa cromada pasante de sobremesa

DETALLES

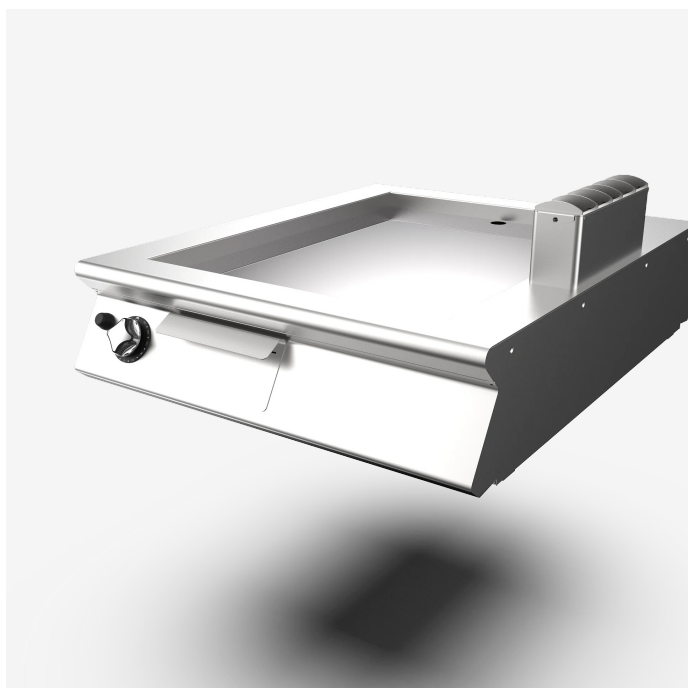

| GAMA | CÓDIGO | MODELO | FUNCIÓN |
|----------|-----------|------------|---------|
| MI - 110 | CRI306050 | NFT109GTMC | Fry Top |

PRODUCTO

Fry-top a gas con placa 1/3 ranurada y 2/3 lisa cromada pasante de sobremesa

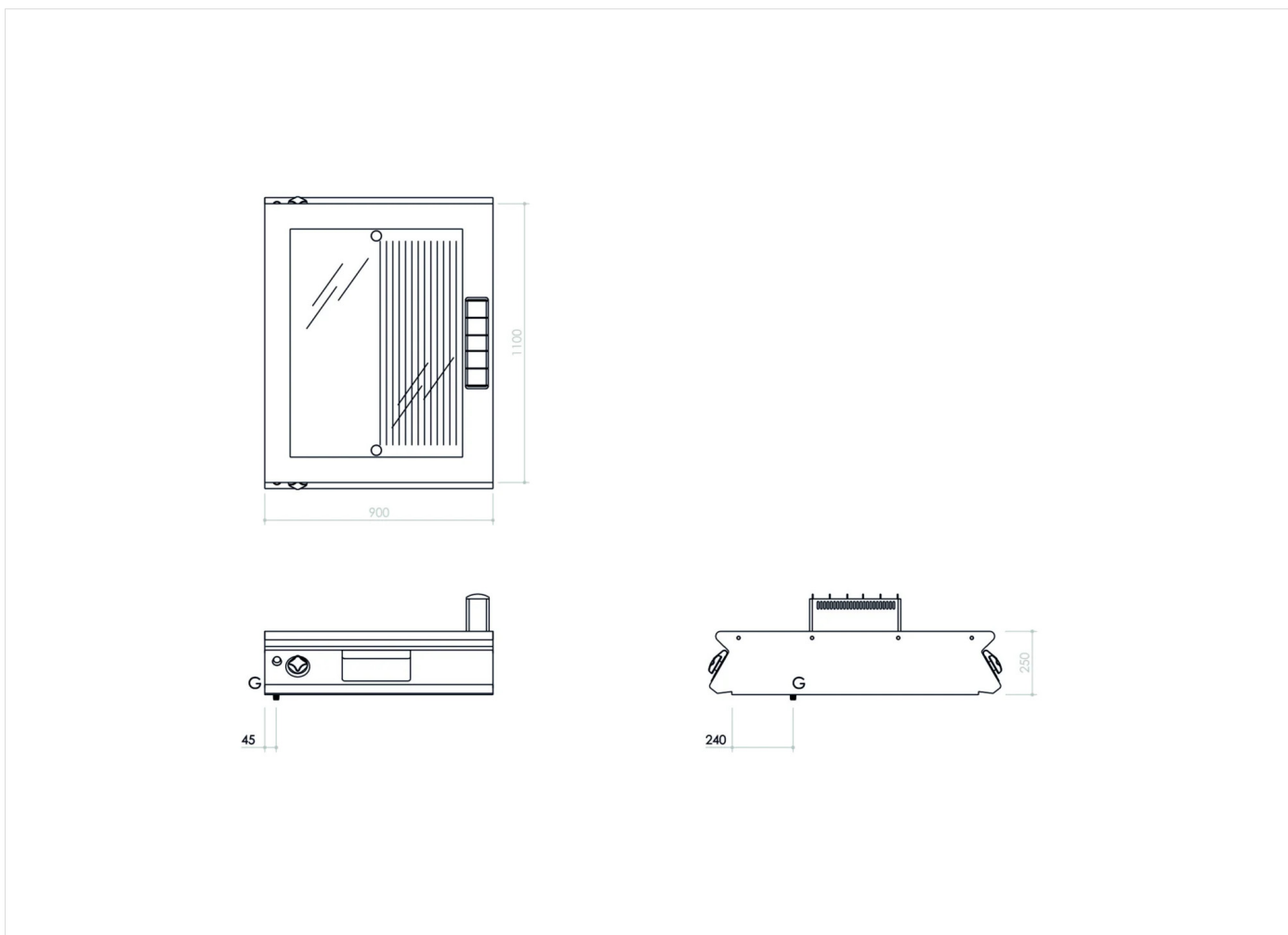

DETALLES TÉCNICOS DE INSTALACIÓN

(G) Llegada Gas: $\text{Ø}1/2''$

