

RANGE	CODE	MODEL	FUNCTION
MO - 70	CRI307440	NEPC78E	Pasta Cookers

ITEM

**Double well electric pasta cooker, 28+28 litre water capacity**



RANGE	CODE	MODEL	FUNCTION
MO - 70	CRI3O7440	NEPC78E	Pasta Cookers

ITEM

Double well electric pasta cooker, 28+28 litre water capacity

DETAILS



RANGE	CODE	MODEL	FUNCTION
MO - 70	CRI307440	NEPC78E	Pasta Cookers

ITEM

**Double well electric pasta cooker, 28+28 litre water capacity**



**TECHNICAL SPECIFICATIONS**

WIDTH (mm):	800
DEPTH (mm):	700
HEIGHT (mm):	870
WEIGHT (Kg):	70
VOLUME (m <sup>3</sup> ):	0.8
EL. POWER (kW):	11.4
VOLTAGE:	380-415 V 3N
COOKING ZONES N°:	2
TANK DIM. (mm):	2x 340x305x325(h)
TANK N°:	2
CAPACITY (L):	28+28
IP GRADE:	IPX4
TEMP. RANGE (°C):	0-100 °C

**DESCRIPTION**

Electric pasta-cooker with two tanks. Made of stainless steel. Deep drawn tanks made of polished AISI 316 stainless steel with a rounded bottom to be cleaned easily. Heating by means of armoured heating elements placed inside the tank to optimise efficiency, which can be tilted to facilitate cleaning the tank. Power regulator to set the temperature. Equipped with a manual-reset safety thermostat. 2 x 28-litre tank, dimensions 30.5x34 cm. Water supply and drain by means of taps at the front. Height adjustable feet made of stainless steel.



RANGE	CODE	MODEL	FUNCTION
MO - 70	CRI307440	NEPC78E	Pasta Cookers

ITEM

**Double well electric pasta cooker, 28+28 litre water capacity**

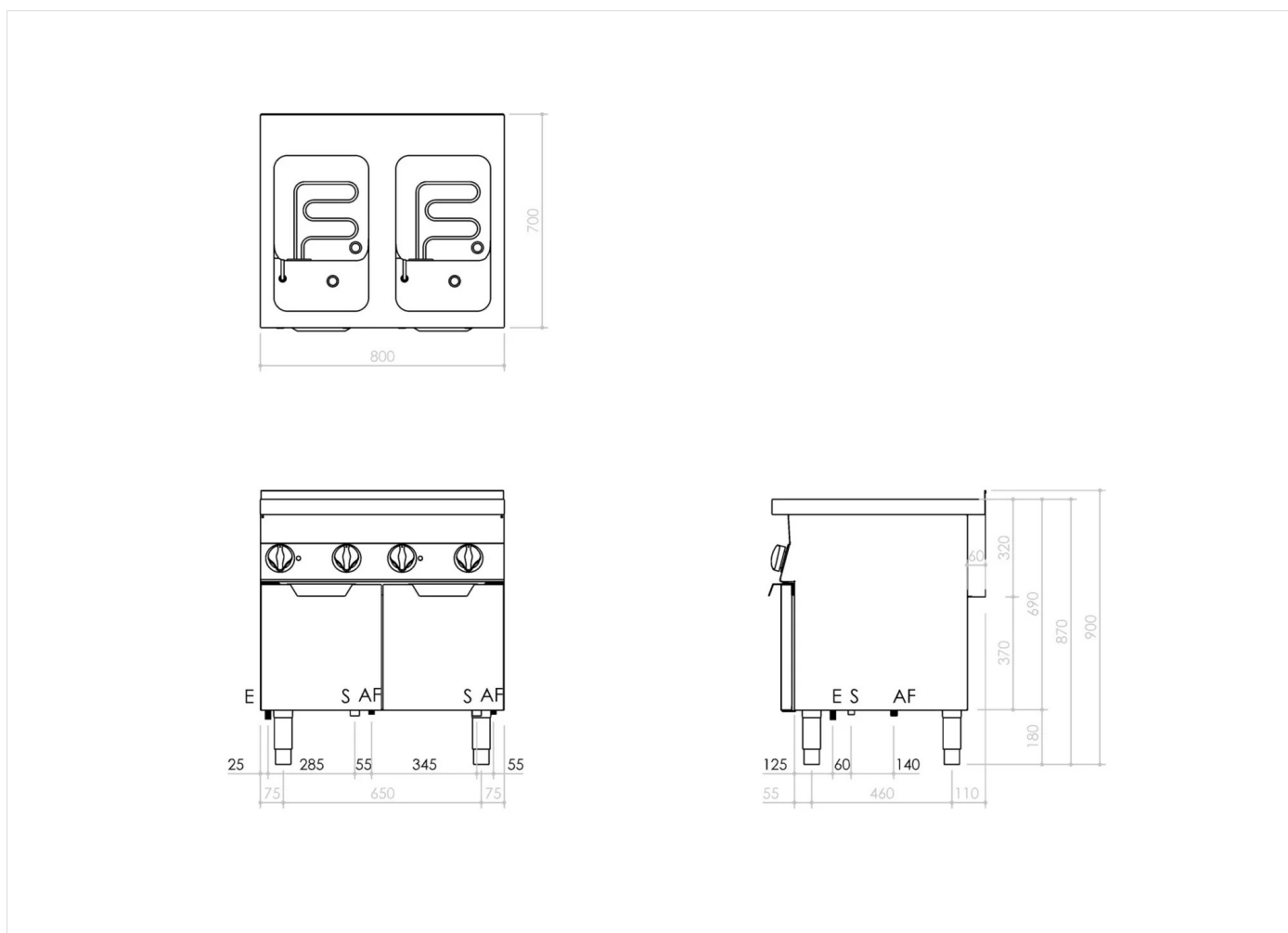

**INSTALLATION SPECIFICATIONS**

(E) Electrical Connection:	380-415 V 3N 50-60Hz
(S) Output Drain:	Ø3/4"

