

| RANGE | CODE | MODEL | FUNCTION |
|------------|---------------|----------|----------|
| Drop-in 60 | MAIO4O242II4O | FTE4ODCB | Griddles |

ITEM

Drop-in electric griddle with smooth plate with control box



| RANGE | CODE | MODEL | FUNCTION |
|------------|---------------|----------|----------|
| Drop-in 60 | MAIO4O242I14O | FTE4ODCB | Griddles |

ITEM

Drop-in electric griddle with smooth plate with control box



TECHNICAL SPECIFICATIONS

| | |
|---------------------------|-----------|
| WIDTH (mm): | 425 |
| DEPTH (mm): | 600 |
| HEIGHT (mm): | 180 |
| WEIGHT (Kg): | 37 |
| VOLUME (m ³): | 0.11 |
| EL. POWER (kW): | 3.9 |
| VOLTAGE: | VAC400 3N |
| COOKING ZONES N°: | 1 |
| COOKING ZONES DIM. (mm): | 396x521mm |
| TEMP. RANGE (°C): | 50-320 |

DESCRIPTION

Electric drop-in fry-top with smooth plate. Front hole for dripping fat drawer. Thermostat to regulate temperature from 50°C to 250°C and manual safety thermostat. Cooking surface 21,9 dm². Warning light to control the appliance's correct working. Fixings, 1 m. cable and scraper included.



| RANGE | CODE | MODEL | FUNCTION |
|------------|---------------|----------|----------|
| Drop-in 60 | MAIO40242II40 | FTE4ODCB | Griddles |

ITEM

Drop-in electric griddle with smooth plate with control box

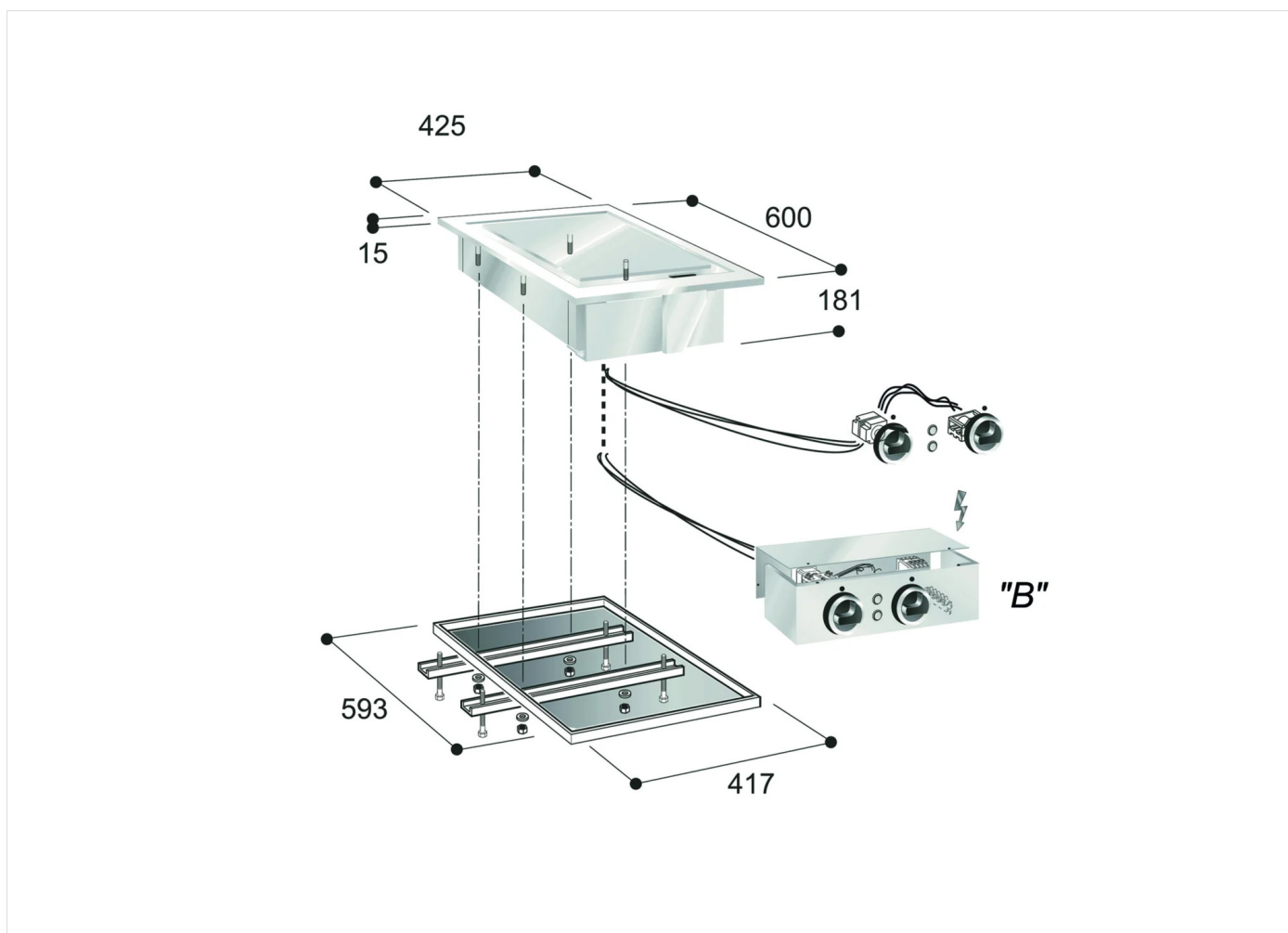

INSTALLATION SPECIFICATIONS

(E) Electrical Connection: VAC400 3N 50/60Hz

