

RANGE	CODE	MODEL	FUNCTION
Drop-in 60	MAIO402422140	FTE6ODC	Griddles

ITEM

Drop-in electric griddle with smooth chromed plate



RANGE	CODE	MODEL	FUNCTION
Drop-in 60	MAIO402422140	FTE6ODC	Griddles

ITEM

Drop-in electric griddle with smooth chromed plate



TECHNICAL SPECIFICATIONS

WIDTH (mm):	625
DEPTH (mm):	600
HEIGHT (mm):	180
WEIGHT (Kg):	55
VOLUME (m ³):	0.15
EL. POWER (kW):	7.8
VOLTAGE:	VAC400 3N
COOKING ZONES N°:	2
COOKING ZONES DIM. (mm):	596x521
TEMP. RANGE (°C):	50-320

DESCRIPTION

Electric drop-in fry-top with smooth chromed plate. Front hole for dripping fat drawer. Thermostat to regulate temperature from 0°C to 260°C and manual safety thermostat. Cooking surface 33 dm². Warning light to control the appliance's correct working. Fixings, 1 m. cable and scraper included.



RANGE	CODE	MODEL	FUNCTION
Drop-in 60	MAIO402422140	FTE6ODC	Griddles

ITEM

Drop-in electric griddle with smooth chromed plate

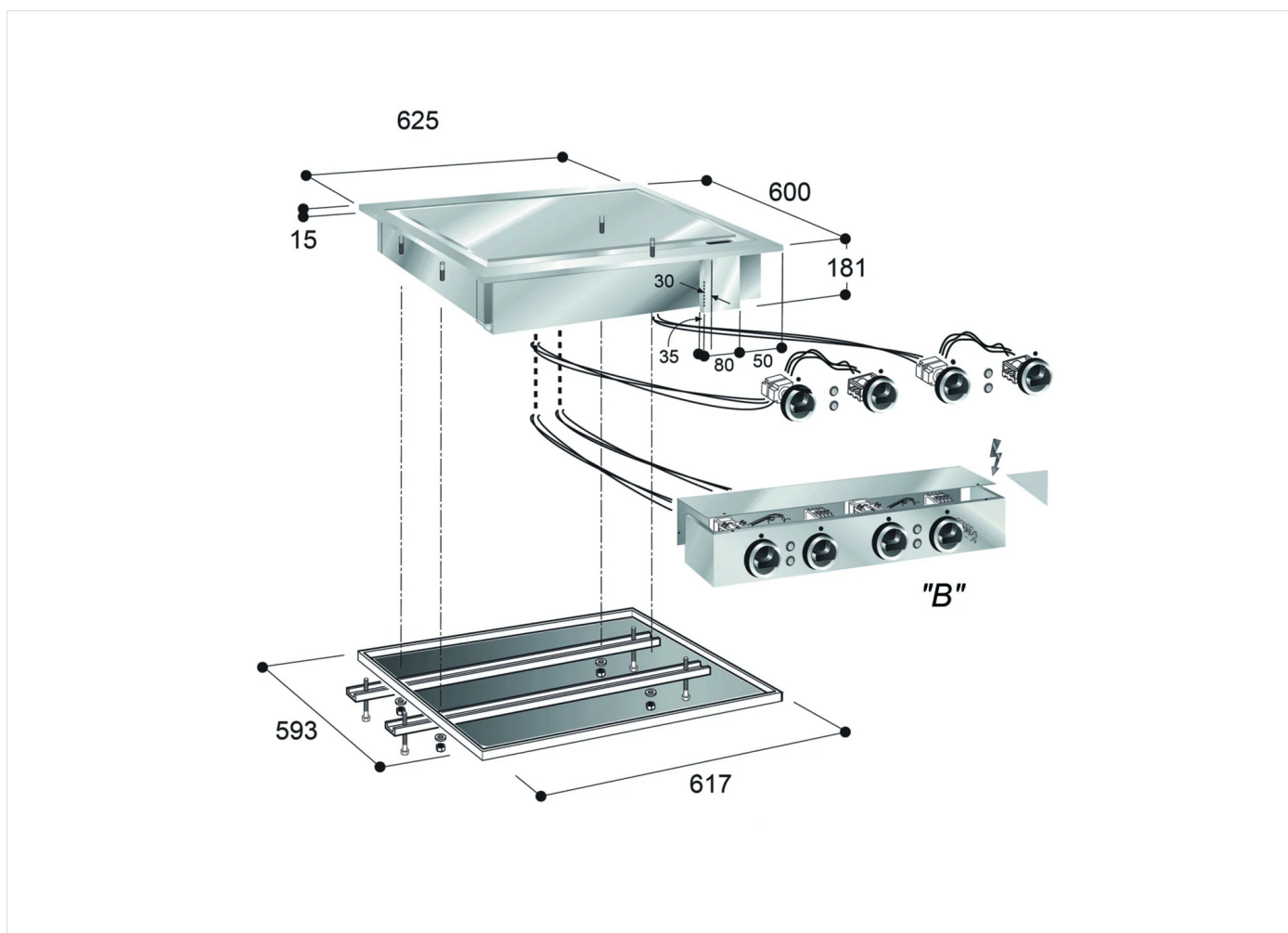

INSTALLATION SPECIFICATIONS

(E) Electrical Connection: VAC400 3N 50/60Hz

