

RANGE	CODE	MODEL	FUNCTION
Drop-in 60	MAIO4O243914O	BSE4ODMB	Hot Container

ITEM

Drop-in infrared chips scuttle with control box



RANGE	CODE	MODEL	FUNCTION
Drop-in 60	MAIO402439140	BSE4ODMB	Hot Container

ITEM

Drop-in infrared chips scuttle with control box



TECHNICAL SPECIFICATIONS

WIDTH (mm):	400		
DEPTH (mm):	600		
HEIGHT (mm):	260		
WEIGHT (Kg):	13		
VOLUME (m ³):	0.11		
EL. POWER (kW):	1		
VOLTAGE:	VAC230 1		
COOKING ZONES N°:	1		
TANK DIM. (mm):	325x530x150(h) mm		
TANK N°:	1		
CONTAINERS MAX N°:	1x GNI/1	CONTAINERS MAX H:	150mm
TEMP. RANGE (°C):	30-90		

DESCRIPTION

Electric drop-in container with perforated false bottom.



RANGE	CODE	MODEL	FUNCTION
Drop-in 60	MAIO402439140	BSE4ODMB	Hot Container

ITEM

Drop-in infrared chips scuttle with control box

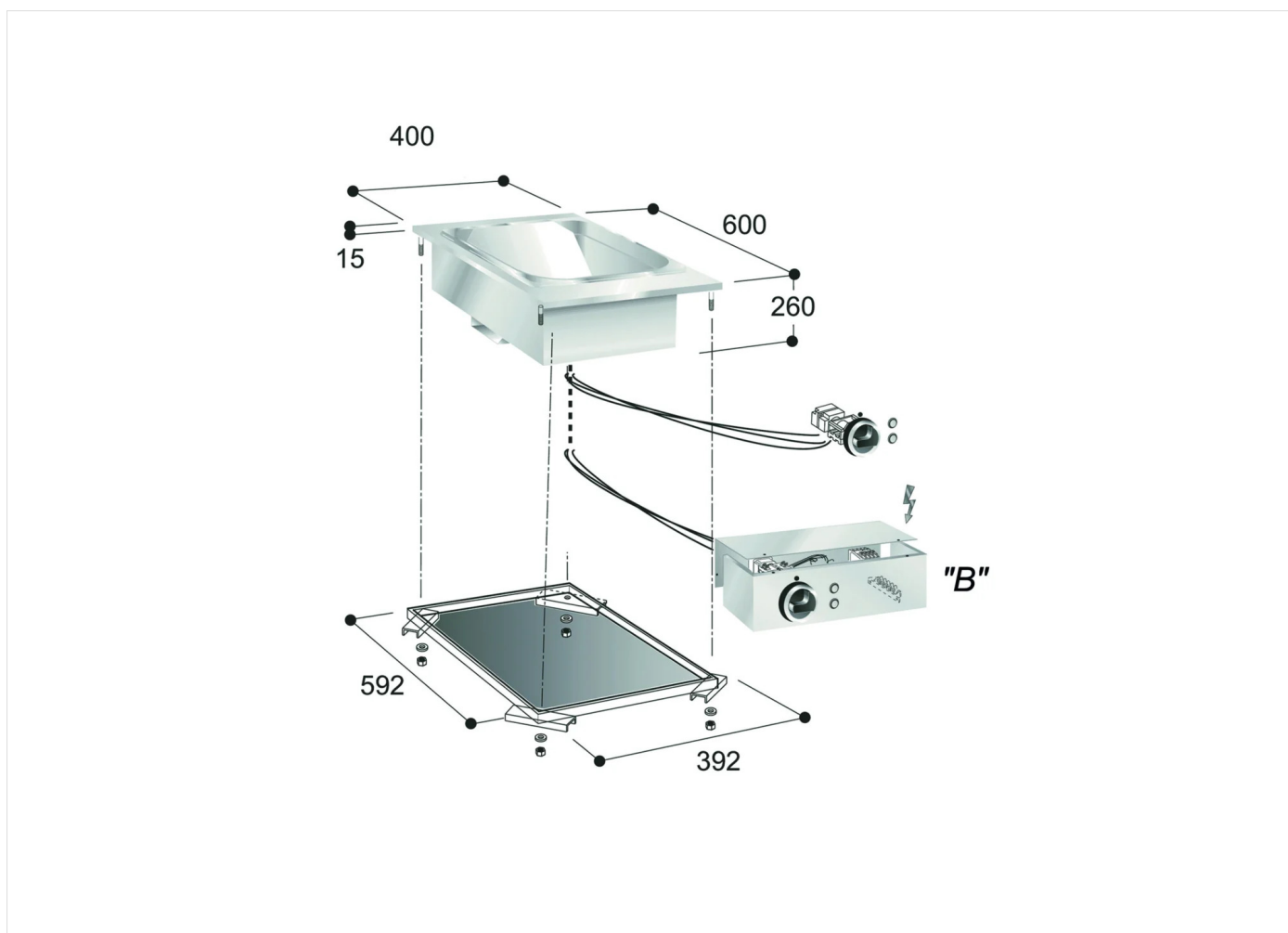

INSTALLATION SPECIFICATIONS

(E) Electrical Connection: VAC230 | 50/60Hz

