

RANGE	CODE	MODEL	FUNCTION
MI - 90	MAMCOOO3180	TP98GFG	Solid Top

ITEM

Gas cast iron solid top plate with removable bullseye gas oven range



RANGE	CODE	MODEL	FUNCTION
MI - 90	MAMCOOO3I80	TP98GFG	Solid Top

ITEM

Gas cast iron solid top plate with removable bullseye gas oven range



TECHNICAL SPECIFICATIONS

WIDTH (mm):	800
DEPTH (mm):	920
HEIGHT (mm):	900
WEIGHT (Kg):	160
VOLUME (m ³):	1
GAS POWER (kW):	19
INTERNAL OVEN DIM. (mm):	570x490x295(h) mm
OVEN CAPACITY:	2x GN 2/1
OVEN POWER (kW):	8
COOKING ZONES N°:	1
COOKING ZONES DIM. (mm):	780x700mm
COOKING ZONE DETAILS:	1x 11kW
OVEN TEMP. RANGE (°C):	0-300

DESCRIPTION

Solid top gas cooker on gas oven in AISI 304 stainless steel. 20/10 pressed steel top with anti-spill front edge, designed for flush alignment with hermetic seal supplied. Top designed to accommodate water column accessory. 780x700 mm radiant hotplate in heavy gauge cast iron with ribs for optimal heat diffusion and central bullseye. Heating occurs by means of a double ring, stainless steel, chromed burner with high rated output to reach 500 °C at the centre of the plate and 200 °C near the edges, complete with a pilot burner with piezoelectric ignition and safety thermocouple. Ergonomic knobs shaped to prevent water infiltration. Gas supply controlled by a thermostatic safety valve. GN 2/1 gas oven with thermostatic control valve providing temperature adjustment from 50°C to 300°C. Stabilised flame burner complete with pilot flame with piezoelectric ignition and safety thermocouple. Stainless steel oven chamber, dimensions 575x700x300h mm. Oven power 8 kW. Heavy gauge enamelled steel oven bottom. Pressed stainless steel oven inner door with labyrinth seal. Appliance equipped with stainless steel adjustable feet.



RANGE	CODE	MODEL	FUNCTION
MI - 90	MAMCOOO3I80	TP98GFG	Solid Top

ITEM

Gas cast iron solid top plate with removable bullseye gas oven range

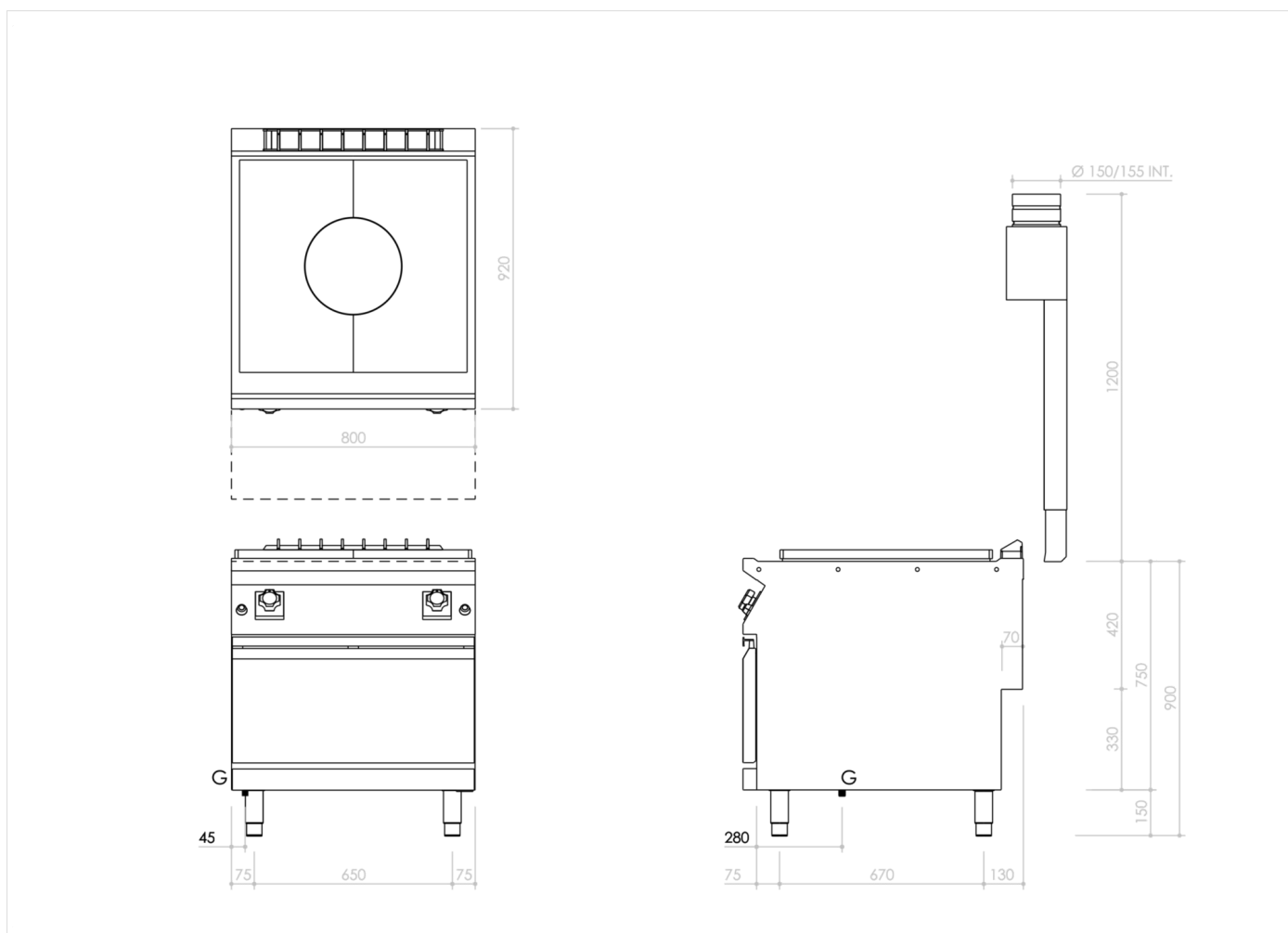

INSTALLATION SPECIFICATIONS

(G) Gas Inlet: $\text{Ø}1/2''$

